

Over 20 Years Of Innovation

R155 High Energy Screener

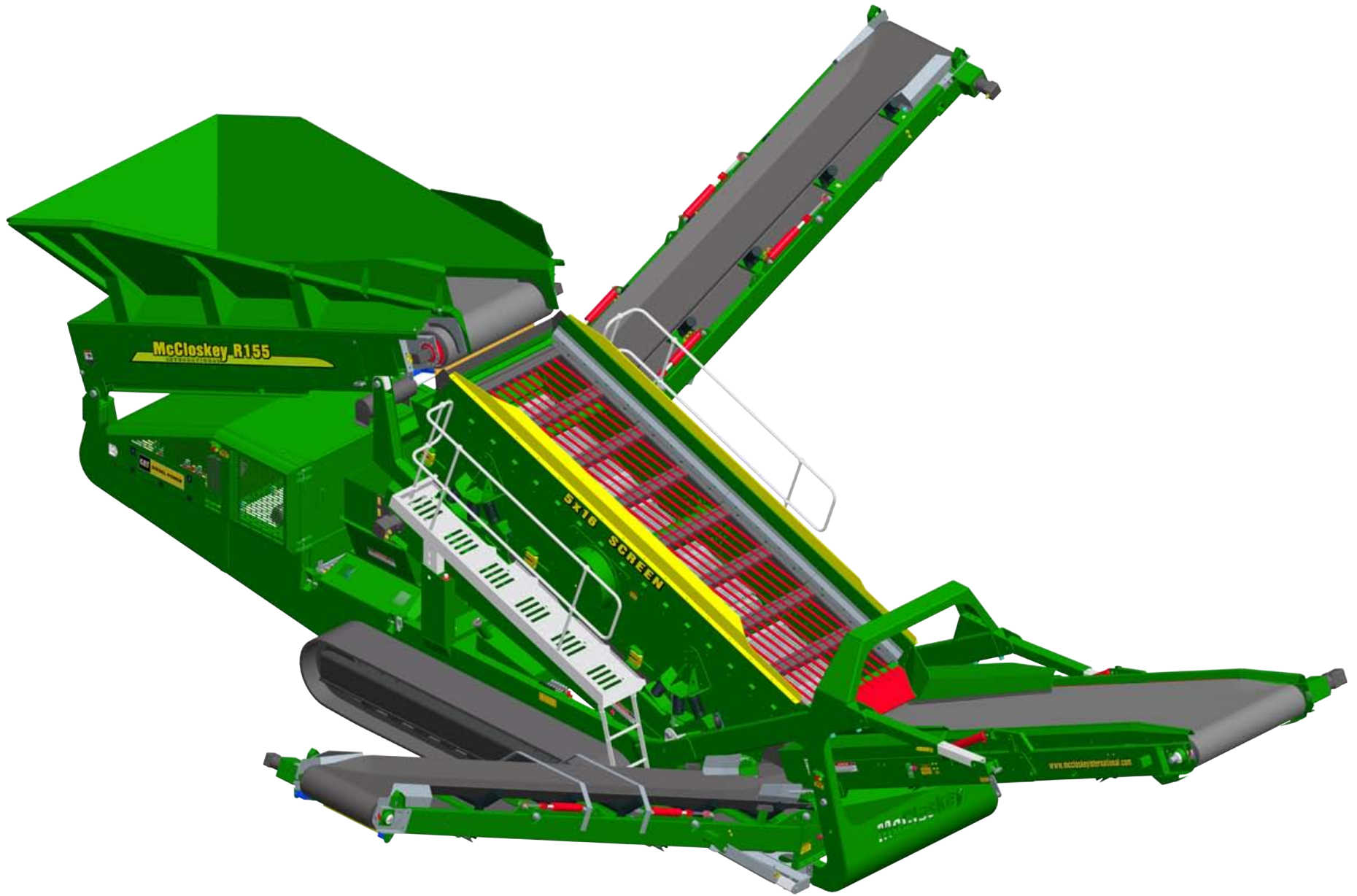

McCloskey
INTERNATIONAL

-  ROCK
-  TOPSOIL
-  SAND
-  GRAVEL
-  RECYCLING
-  COAL
-  DEMO

Over 20 Years Of Innovation - New Opportunities

R155 High Energy Screener

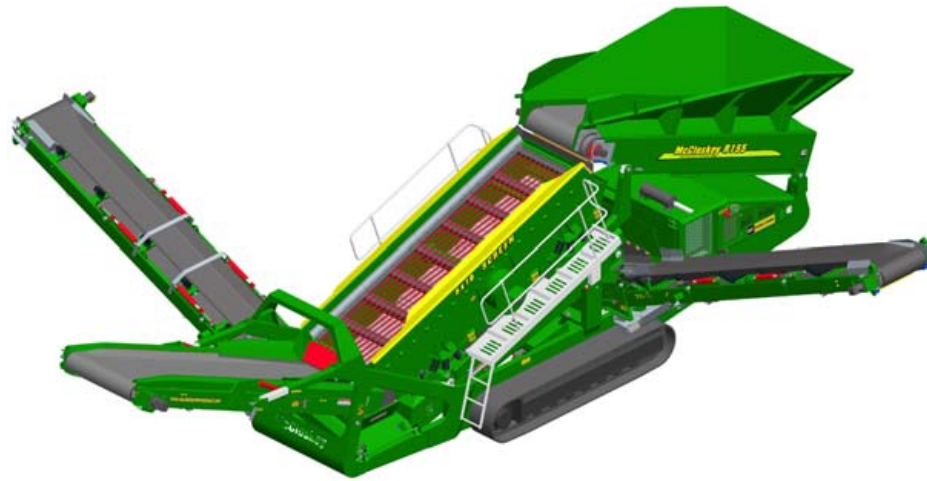

With a class leading **125hp CAT** power-plant, heavy duty engineering and a **10 minute setup time**, the **R155** is consistent with the McCloskey philosophies that made us the world leader in trommels.

Equipped with a high energy double deck **16' x 5' screenbox** fed by a **10.5 cubic yard hopper**, the **R155** will accommodate the needs of portable flatdeck operators with the heaviest duty applications.

Boasting the largest screenbox and hopper in its class, sized exactly to what we claim, the **R155** ensures that your McCloskey representative need never fear your tape measure!

Born of a dedicated flatdeck design bureau that comprises some of the industry's most experienced engineers. The highly advanced **R155** is designed to give McCloskey International and our customers unrivalled superiority in vibratory screening plants.

The R155's **open feed design** and heavy duty build gives it the ability to tackle a massive range of applications from **heavy aggregates** to **construction & demolition waste**.

The **enlarged engine bay** gives room for two mechanics to **stand upright** and **fully service** the CAT engine and the primary hydraulics package.

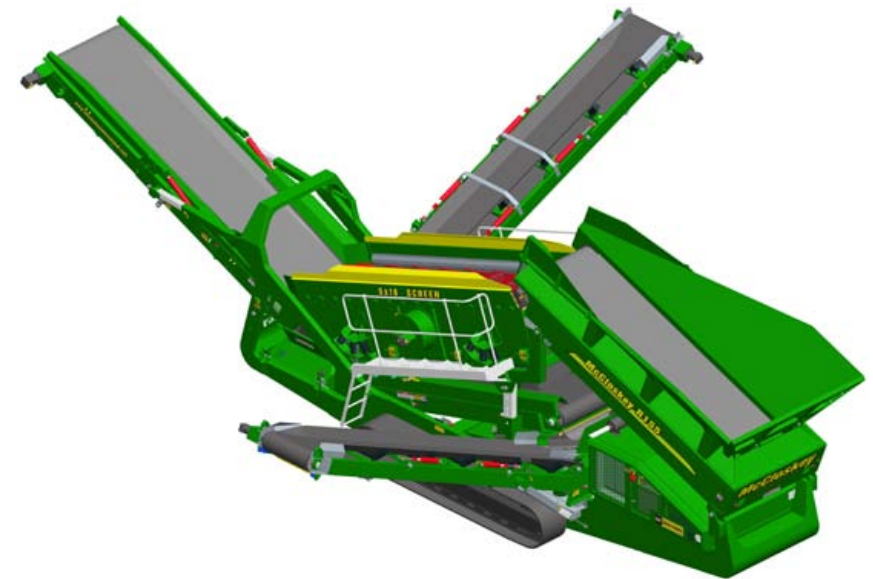

McCloskey

INTERNATIONAL

New Technologies

16' x 5' High Energy Screenbox

Finger Deck
Option

At the heart of the **R155** is the new McCloskey **16' x 5'** heavy duty screenbox which incorporates the latest version of our **High Energy Screenbox** technology to ensure massive throughput and resilience in any type of operation:

- **True 16' x 5'** top deck & **True 15' x 5'** bottom deck
- Class leading **155 square feet** of actual screen area
- Large diameter heavy duty bearings
- Side tensioned top deck with quick release
- End tensioned bottom deck
- **Hydraulically lifting** for easy access to the bottom deck
- Adjustable from **10mm @ 950RPM** to **6mm @ 1,130 RPM**

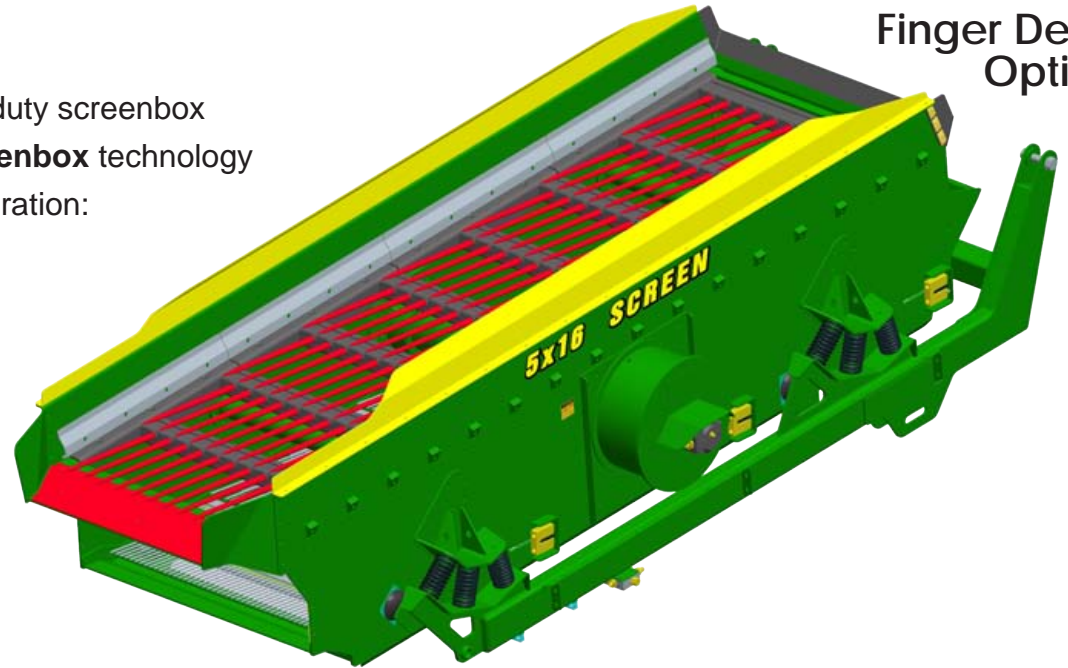

Optional Configurations

Bofar Bar Deck



Woven Mesh Deck

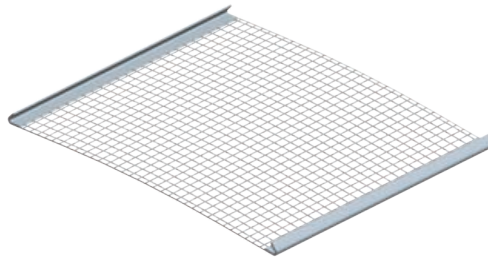

Punch Plate (Standard)

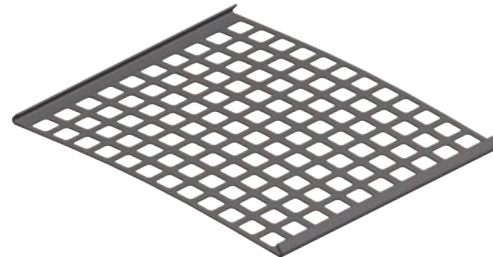

Hardox Plate Feeder

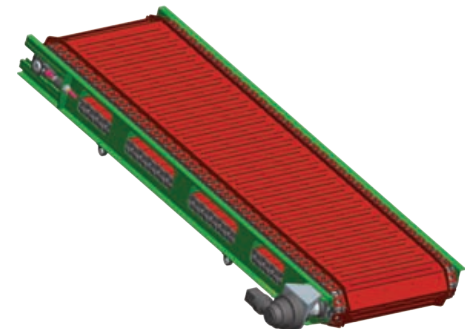

The McCloskey engineering team is constantly striving to improve our products in order to deliver world beating machines of the highest possible quality. As such, the features & specifications listed here are subject to change & development. Ask your authorised McCloskey representative for the latest information.

Transport

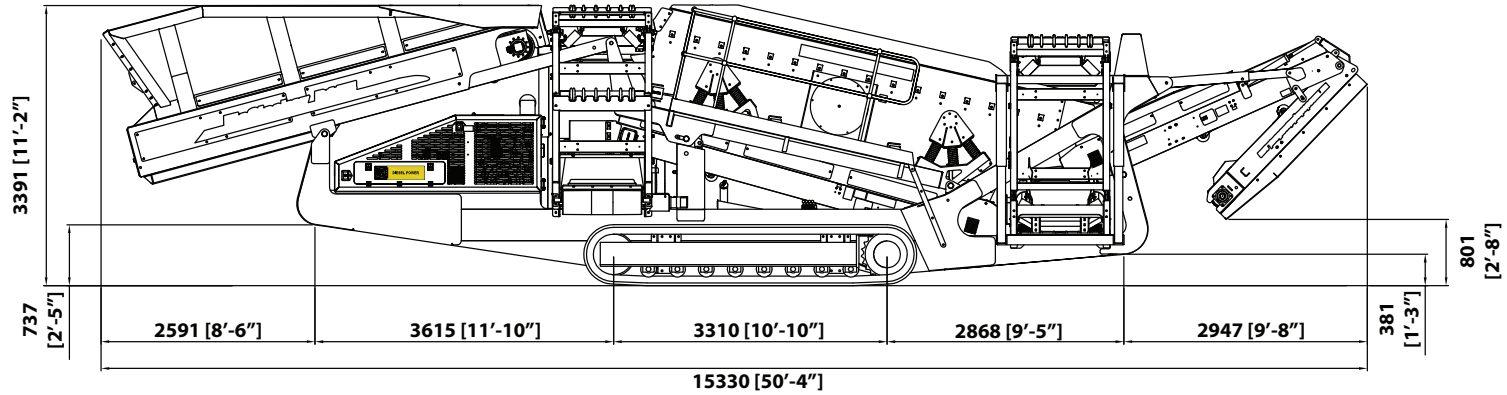

Estimated Gross Weight : 34,000 kg (74,960 lb)
 Width: 2.90m (9'-6")

Working

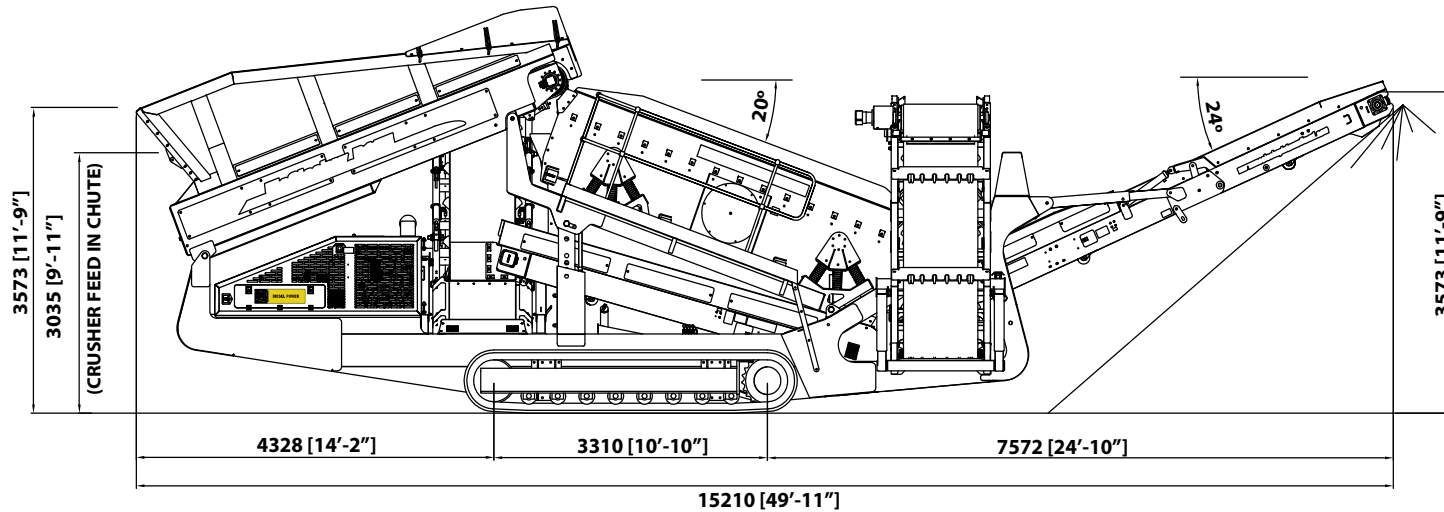

www.mccloskeyinternational.com

McCloskey

INTERNATIONAL

North America & International

☎ 1-877-TROMMEL
 ☎ (705) 295-4925
 ☎ (705) 295-4777
 📧 mccloskey@mccloskeyinternational.com

UK & Europe

☎ +44 (0) 2887-740-926
 ☎ +44 (0) 2887-747-242
 📧 salesuk@mccloskeyinternational.com